



Designed with passion and dedication in the United Arab Emirates



ibtibot

FALCON KIT

Raspberry Pi Compatible

+13
SUITABLE AGE



Copyright © 2019 Ibtikar Edu Tech Solutions

All rights reserved. No part of this publication may be reproduced or distributed in any form or by any means, or stored in a database or retrieval system, without the prior written consent of Ibtikar Edu Tech Solutions, including, but not limited to, network storage or transmission, or broadcast for distance learning, except in the case of brief quotations embedded in critical articles or reviews.

Exclusive rights by Ibtikar Edu Tech Solutions for manufacture and export. This book cannot be re-exported from the country to which it is sold by Ibtikar Edu Tech Solutions.

While the advice and information in this book is believed to be true and accurate at the date of publication, neither the author nor the publisher can accept any legal responsibility for any errors or omissions that may be made. The publisher makes no warranty, express or implied, with respect to the material contained herein.

Ibtikar Edu Tech Solutions, and its dealers and distributors will not be held liable for any damages caused or alleged to be caused directly or indirectly by this book.

Ibtikar Edu Tech Solutions has endeavored to provide trademark information of the companies and products mentioned in this book by the appropriate use of capitals. However, Ibtikar Edu Tech Solutions cannot guarantee the accuracy of this information.

The Power of the Falcon

The Ibtikar team is excited to announce the release of their latest Ibtibot hardware for education, the amazing **Falcon Kit**. Unique in design and educational value this advanced kit includes an Ibtikar designed Arduino (Mega compatible) Shield called the Falcon Hat, which is designed to pair with the Raspberry Pi 3 Model B+, opening pathways to an endless range of digital maker projects.

The Falcon Kit unlocks the world of **'Making'** by stimulating curiosity, imagination and creativity, encouraging you to take risks with your designs and to develop a growth mindset enabling today's **Makers** to be tomorrow's **Inventors**.

Learning by creating and making encourages you, the Maker, to think creatively and to apply knowledge to build on real-life projects and develop new and exciting ones.

2

Combining the power of the Raspberry Pi with an advanced Arduino Mega compatible HAT, the Falcon is the perfect example of a compact, high-end robotics and automation development platform and can be used in an endless range of experiments and projects such as remote-control cars, robots and drones.

With robotics and advanced electronics part of everyday life, tomorrow's automated world will need inventors, innovators and leaders with the abstract thinking, creative problem solving and practical technical skills that the Falcon Kit inspires.

Begin challenging yourself and examine your world through critical and creative thinking using the Falcon Kit. Here is where your journey as an inventor begins.

Behind every great invention is a simple idea.

Ibtikar Team

Falcon Kit Contents

1. Ibtikar Falcon Hat
2. Raspberry Pi 3 Model B+
3. 32 GB Micro SD Card with custom configured Linux OS
4. Power Supply Unit with ON/OFF Switch (British Plug)
5. Retractable LAN Cable (3m)
6. Dual Fan with Heat Sinks
7. Acrylic Case with Rubber Feet, standoffs and screws
8. 40 Pin GPIO Male to Female Ribbon Cable (12cm)
9. Expansion Header for direct connection of the Falcon Hat to the Pi

Ibtikar Falcon Hat

The Ibtikar *Falcon Hat* (*Arduino compatible*) is specifically designed to pair with the Raspberry Pi 3 Model B+. The pairing of the two boards allows for the expansion of the Pi capabilities for more complex and varied projects.

The Falcon Hat features include:

- ◉ Arduino compatible pin mapping (ATmega2560 Chip)
- ◉ Compatible with Arduino standard shield and sensors
- ◉ System voltage: 5V
- ◉ Falcon Hat can be programmed using UART or SPI through the Pi
- ◉ All chips communicate using I2C or SPI, (it is possible to control the chips by Pi or Arduino)

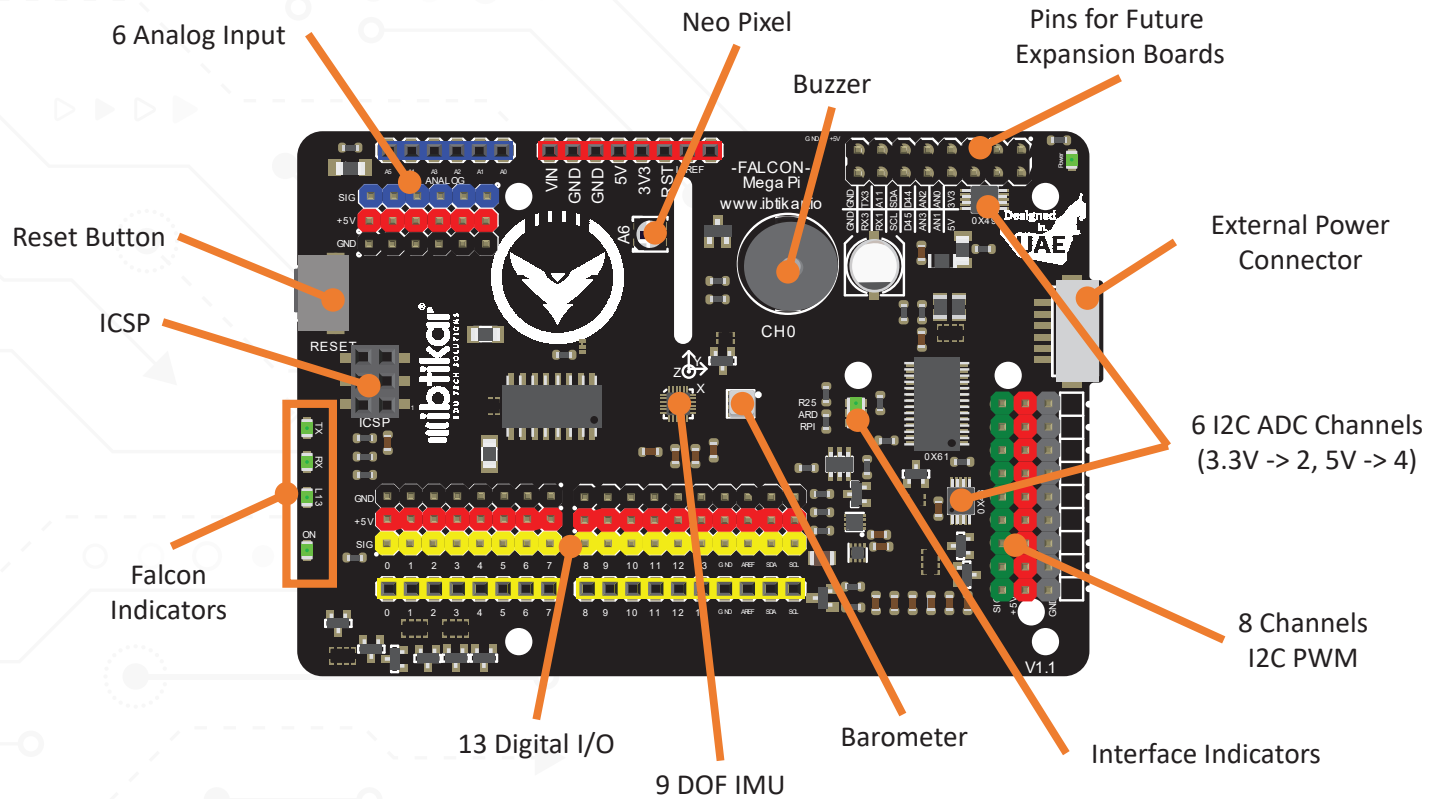

Compatibility

The Falcon Hat is compatible with the RPi 3 B+ and any other RPi that has the same number of pins and the same pin mapping.

Raspberry Pi 3 Model B+

Developed in the UK, the Raspberry Pi is a credit card sized computer that allows the student to explore computing, and to learn programming using languages like Scratch and Python.

The Raspberry Pi provides the student with the capacity to interact with the outside world. The user can program the Pi to control different functions in a wide range of digital maker projects.

The latest to be released in the Raspberry range, is the Raspberry Pi 3 Model B+.

This improved Raspberry model is powered by a 64-bit quad core processor running at an increased speed of 1.4GHz.

Other features include dual band 2.4GHz and 5GHz wireless LAN, Bluetooth 4.2/BLE, faster Ethernet and PoE capacity via a separate PoE HAT.

Processor

- Broadcom BCM2837B0, Cortex-A53 (ARMv8) 64-bit SoC @ 1.4GHz

Memory

- 1GB LPDDR2 SDRAM

Connectivity

- 2.4GHz and 5GHz IEEE 802.11.b/g/n/ac wireless LAN, Bluetooth 4.2, BLE
- Gigabit Ethernet over USB 2.0 (maximum throughput 300 Mbps)
- 4 USB 2.0 ports

Access

- Extended 40-pin GPIO header

Video and sound

- Full-size HDMI
- CSI camera port for connecting a Raspberry Pi camera
- DSI display port for connecting a Raspberry Pi touchscreen display
- 4-pole stereo output and composite video port

Multimedia

- H.264, MPEG-4 decode (1080p30); H.264 encode(1080p30); OpenGL ES 1.1, 2.0 graphics

SD card support

- Micro SD port for loading your operating system and storing data

Input power

- 5V/2.5A DC power input
- 5V DC via GPIO header
- Power-over-Ethernet (PoE) support (requires separate PoE HAT)

Warnings

- Raspberry Pi 3 Model B+ should be operated in a well-ventilated environment.
- The product should be placed on a stable, flat, non-conductive surface or used with the Falcon Acrylic Case.
- Do not expose to water or moisture or place on a conductive surface while in operation.
- Do not expose to heat.
- Avoid handling the circuit board.
- Raspberry Pi 3 Model B+ works best in normal ambient temperatures.

Micro SD Card

- The Raspberry Pi provided with the Falcon Kit comes with a pre-programmed SD storage card which provides a customised and configured Linux operating system and can be used to install apps and files.

Power Supply Unit

- The power supply provided with the Falcon Kit has an ON/OFF switch and a micro USB connector (the same found on many mobile phone chargers)
- Input: 100-240V AC 50/60Hz
- Output: 5V, 2.5A
- UL certified

Retractable LAN Cable (3m)

- CAT5e compatible cable suitable for use with the Pi
- RJ45 to RJ45

Dual Fan with Heat Sinks

- The cooling fan with heat sinks is high speed and low noise and ensures efficient and swift cooling of the Pi. Under normal conditions, the Pi will not overheat, but the cooling fan ensures all components are not at risk.
- The dual fans with heat sinks are specially designed to fit the Raspberry Pi 3 Model B+.

Package Includes

- 1 x Dual fan with aluminium heat sink
- 1 x Aluminium mini heat sink module
- 1 x Copper heat sink

Acrylic Case

8

Package Includes

- 1 x Base
- 1 x Top cover
- Nylon screws and stand-offs

40 Pin GPIO Male to Female Ribbon Cable

This cable allows to mount the Falcon Hat and the Raspberry Pi side by side.

Expansion Header

This header allows to mount the Falcon Hat directly on top of the Raspberry Pi.

Assembly

STEP 1: Set up your Raspberry Pi.

1.1 Insert SD card.

1.2 Install fan & heat sinks. Ensure the red and black cables are closer to edge of the Pi.

1.3 Connect the 40-pin ribbon cable to the RPi side. Ensure the connector (the small piece of plastic protruding from the header body) key faces the heat sink.

STEP 2: Assembling the base, base screws and standoffs (Refer to the following image):

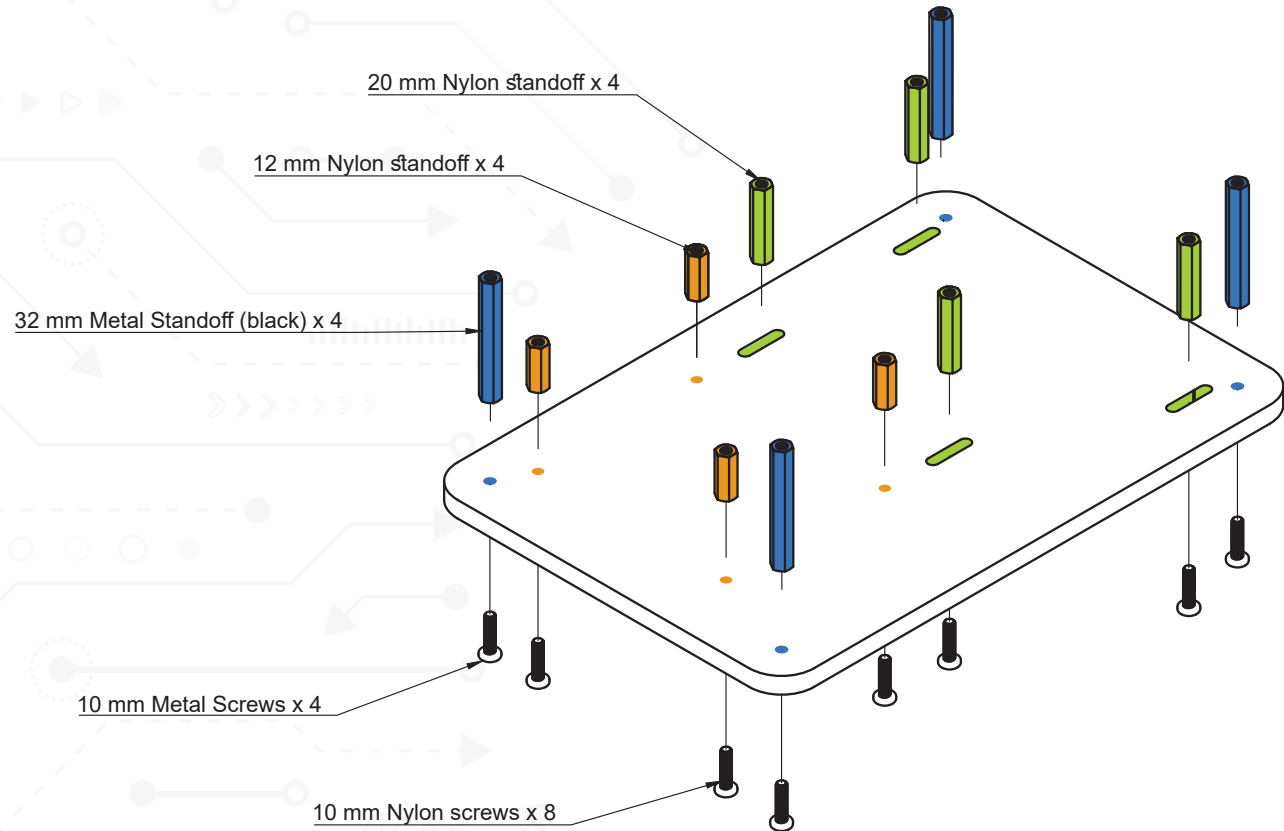

Note: Colour coding on this image is for easy reference and not related to the colour of screws and standoffs.

2.1 On the underside of the acrylic base, insert 4 x 10mm nylon screws at the **orange** location shown in the image. On the top side, twist 4 x 12mm nylon stand-offs onto the screws.

2.2 On the underside of the acrylic base, insert 4 x 10mm nylon screws at the **green** location shown in the image. On the top side, twist 4 x 20mm nylon stand-offs onto the screws.

2.3 On the underside of the acrylic base, insert 4 x 10mm metal screws at the **blue** location shown in the image. On the top side, twist 4 x 32mm metal stand-offs onto the screws.

STEP 3: Mount the Pi on the 4 **orange** stand-offs and fix it with 4 x 6mm nylon screws.

STEP 4: Connect the Pi to the Falcon Hat.

4.1 Connect the dual fan power cable to the bottom of the Falcon Hat. The red cable connects to the +5V and the black cable connects to ground (GND).

4.2 Connect the other end of the ribbon cable to the Falcon. Ensure the key on the Falcon matches the slot on the cable connector.

STEP 5: Mount the Falcon on the 4 **green** stand-offs and fix with 2 x 6mm nylon screws on the side closest to the Pi (the unscrewed stand-offs provide pillar support to the Falcon).

STEP 6: Attach the acrylic top to the 4 **blue** stand-offs. Ensure the rectangular opening is above the Falcon.

STEP 7: Place the acrylic top on the standoffs marked **blue** in the image. Fix the top to the standoffs using 4 x 10mm metal screws.

STEP 8: Ensure the Falcon is aligned in the rectangular space. You can adjust the Falcon by shifting the **green** standoffs in the slots provided on the acrylic base.

STEP 9: Attach the 4 rubber feet to the bottom of the acrylic base.

You have now completed assembly of the Acrylic development case.

Mounting the Falcon on the Pi Directly

The Falcon Hat can be mounted on the top of the RPi directly with the help of an expansion header. This configuration helps if you are building a certain application where space is limited; like a vehicle for example. In such configuration you do not need the acrylic base.

Start Using the Setup

At this point, you are ready to power the setup and start using it.

STEP 1: Connect the ethernet cable to the Pi ethernet connector. Connect the other end to your computer ethernet connector.

STEP 2: Connect the power supply unit to the wall adapter. Connect the other end to the Pi power connector.

STEP 3: Turn the power supply unit ON. You should see some indicators on the Falcon and the Pi blinking.

STEP 4: On your computer, open a web browser and type the following as is:

192.168.137.53/guacamole/

STEP 5: A page should open asking for the username and the password. If you get an error that you cannot reach the required page, then give it some time until the Pi finishes booting.

STEP 6: Type **pi** for both the username and the password.

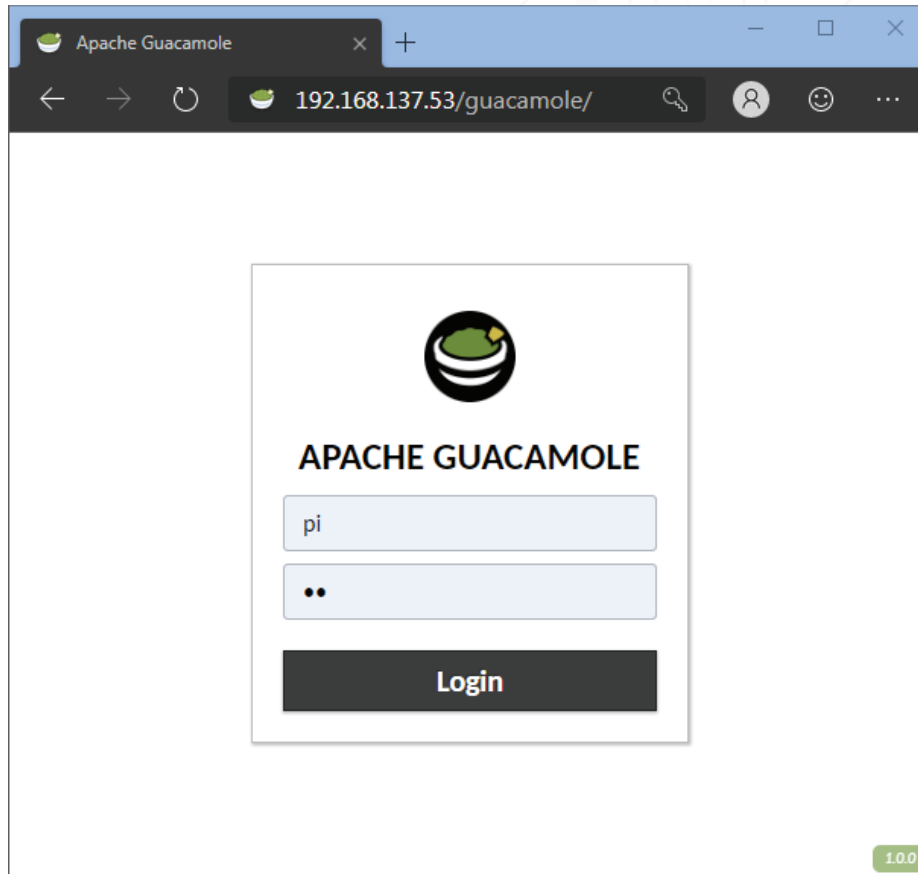

STEP 7: A new page will open with two options. The first option '*desktop*' allows you to use the visual interface on the Pi and logs directly without the need to enter a password. The other option '*terminal*' allows you to use the command line and requires a username and a password. The username is **pi** and the password is **ibtikar**.

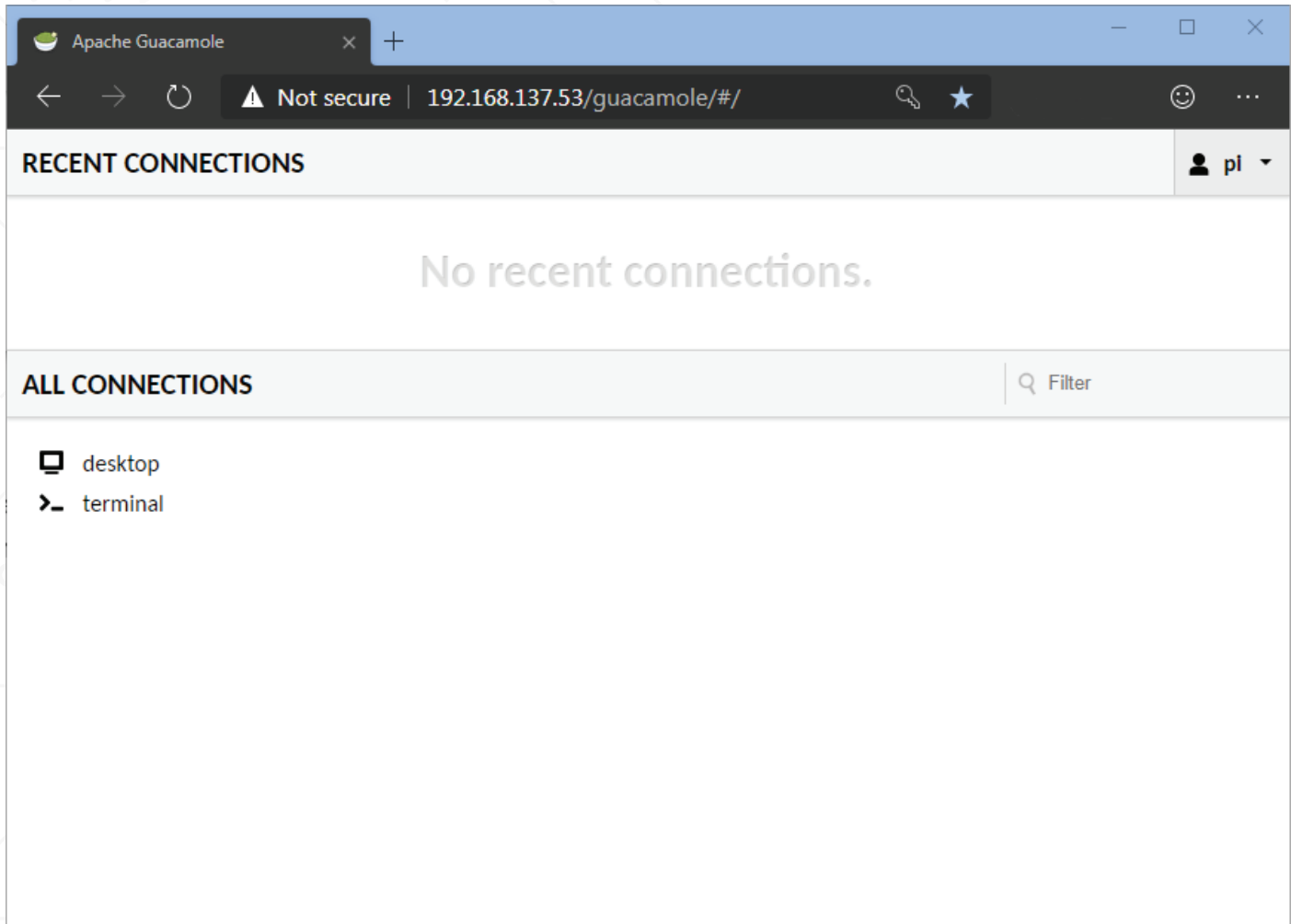

Warranty

The Falcon kit comes with a 1 Year limited warranty that includes:

- Standard warranty as specified by [Element14](#) for Raspberry Pi 3 Model B+
- 12-month warranty on Ibtikar Falcon Hat
- 6 months warranty on Power Supply and LAN Cable

Warranty does not include repair, replacement, or provision of refunds in the following instances:

- If the alleged defect arises because user has altered or repaired the item without the prior written consent or authorisation from Ibtikar
- If user did not follow any applicable instructions for proper storage, usage, or maintenance of the product;
- If user has failed to notify Ibtikar of any defect where the defect should have been reasonably apparent on inspection
- If user fails to notify Ibtikar of the defect within warranty period

